

PREMIUM

OPTION 1
Base appoggio universale
Universal Fit

- I** ISTRUZIONI DI MONTAGGIO:
- GB** FITTING INSTRUCTIONS:
- F** INSTRUCTIONS D'INSTALLATION:
- D** MONTAGEANLEITUNG:
- E** INSTRUCCIONES DE INSTALACIÓN:

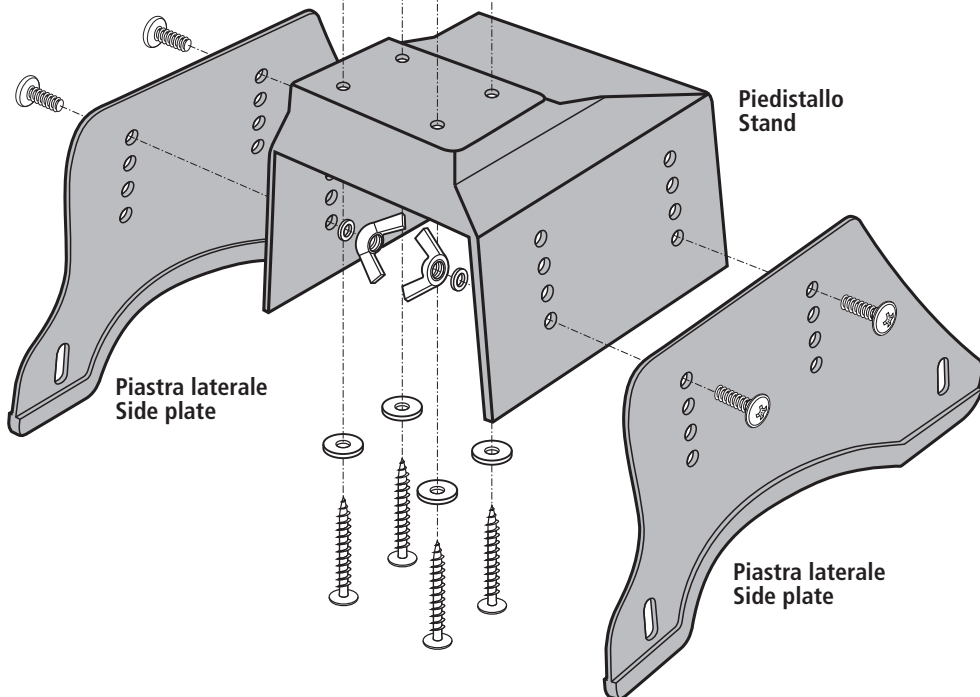
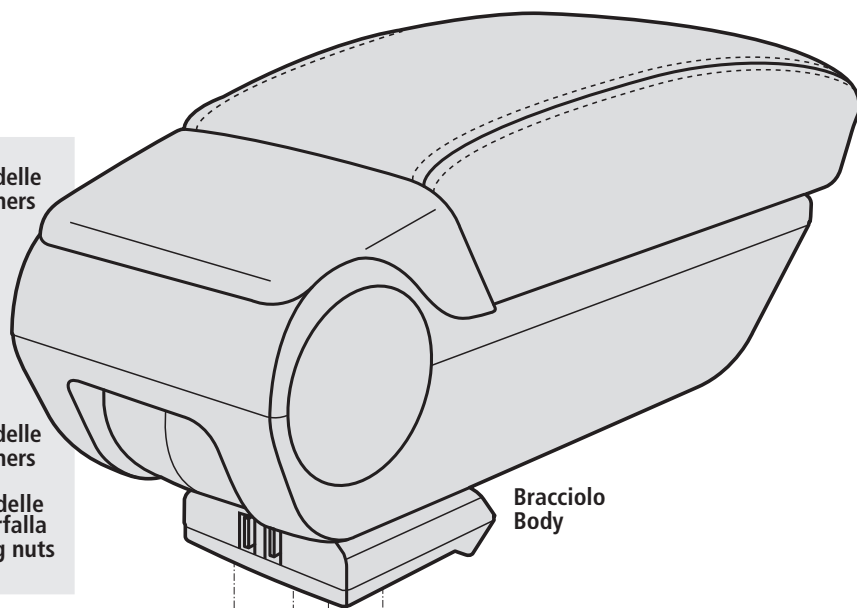
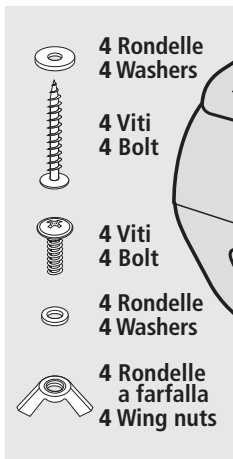
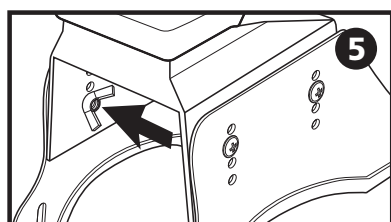
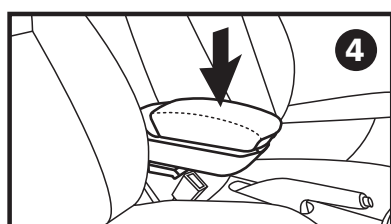
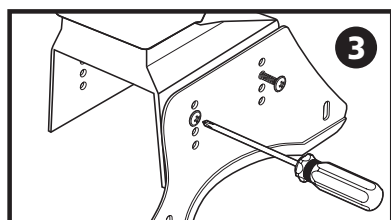
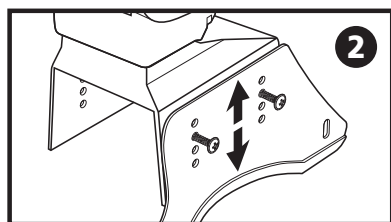
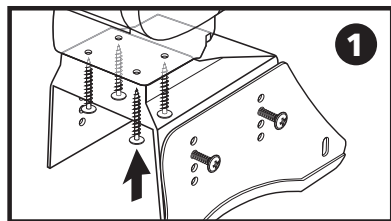

I

1. Utilizzando le 4 viti lunghe con le rondelle, avvitare il piedistallo alla console porta oggetti. Posizionare le piastre laterali con i lati corti e fori ovali sotto alla console e con la parte sporgente rivolta verso il fronte. Non serrare le viti.
2. Decidere l'altezza della console.
3. Avvitare i due piedi del piedistallo alle piastre laterali precedentemente avvitate. Infilare la vite nei fori corrispondenti all'altezza desiderata.
4. Posizionare la console tra i due sedili.
5. Serrare le 4 rondelle a farfalla sotto alla console.

GB

1. Using the enclosed 4 long screws with the washer with wing nuts, screw the adaptor to the console. Position the two plates with the short sides and the oval holes under the console box and with the protruberant portion toward the front. Do not tighten the screws.
2. Decide the height of the console.
3. Screw the two feet of the stand to the plates previously screwed to the console. Insert the screw into the holes corresponding to the desired height.
4. Please position the console between the two seats by adjusting the opening of the stand for better fit to the size and shape of the car floor.
5. Tighten the four wing nuts under the console.

F

1. En utilisant les 4 longues vis avec rondelles et papillon, visser le piedestal à la console d'objets. Positionner les plaques latérales avec les petits côtés et trous ovales au-dessous de la console et la partie saillant vers l'avant. Ne pas serrer les vis.
2. Décidez la hauteur de la console.
3. Vissez les deux pieds du socle aux plaques précédemment vissé à la boîte. Insérer la vis dans les trous correspondants à la hauteur désirée.
4. Placez la console entre les sièges en ajustant l'ouverture du piedestal pour mieux les adapter à la forme et la taille de l'espace du chassis.
5. Serrer les 4 papillons sous la console.

D

1. Befestigen Sie den Sockel mit den 4 langen Schrauben mit Unterlegscheiben an die Konsole. Die kurze Seite und ovalen Löcher der Platten müssen unter der Konsole angeschraubt werden, wohingegen muss die hervorstehende Teil nach vorne positioniert werden. Ziehen Sie die Schrauben nicht kräftig an.
2. Bestimmen Sie die Höhe der Konsole.
3. Schrauben Sie beide Sockel an die zuvor montierte Platten, und stecken Sie die Schraube je nach gewünschter Höhe in den entsprechenden Löchern.
4. Positionieren Sie die Konsole zwischen den Sitzen. Regulieren Sie die Breite des Sockels, so dass er sich optimal dem Boden des Autos anpasst.
5. Ziehen Sie die 4 Flügelschraube unter der Konsole an.

E

1. Utilizando los 4 tornillos largos con arandelas y mariposa, atornillar el pedestal a la console de objetos. Coloque las placas laterales a la posición con los lados cortos y agujeros ovales en la consola y la parte que sobresale hacia la parte frontal. No apriete los tornillos.
2. Decida la altura de la consola.
3. Atornille los dos pies de las placas del pedestal a las placas laterales previamente atornilladas a la caja. Inserte el tornillo en los orificios correspondientes a la altura deseada.
4. Coloque la consola entre los dos asientos mediante el ajuste de la abertura del pedestal para ajustarse mejor a la forma y el tamaño del espacio en el piso.
5. Apriete las 4 mariposas bajo la consola.

PREMIUM

OPTION 2
Attacchi su misura
Custom Fit

- I** VEDI ISTRUZIONI DEL KIT DI MONTAGGIO SPECIFICO
- GB** SEE SPECIFIC INSTRUCTIONS MANUAL IN THE CUSTOM-FIT BASE
- F** VOIR LES INSTRUCTIONS POUR LE KIT DE MONTAGE SPÉCIFIQUE
- D** SIEHE DIE ANWEISUNGEN DES SPEZIFISCHEN ADAPTE KITS
- E** VÉASE INSTRUCCIONES PARA EL KIT DE MONTAJE ESPECÍFICO



Compatibile per / Compatible for

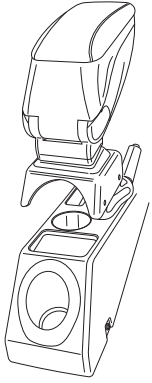

ALFA ROMEO

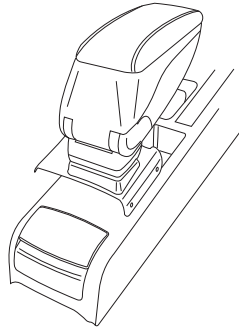

AUDI

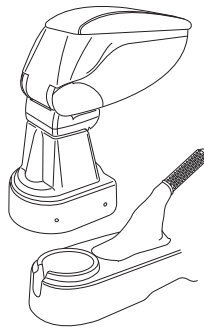

CHEVROLET

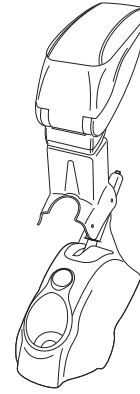

CITROEN

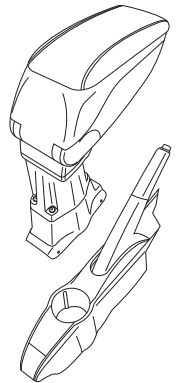

FIAT

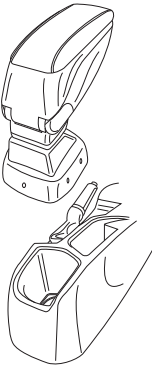

FORD

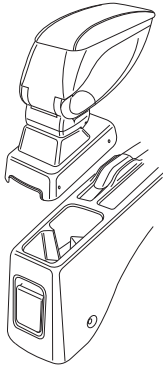

HONDA

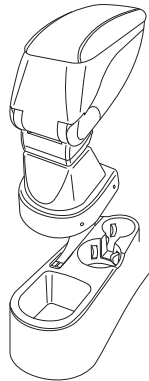

HYUNDAI

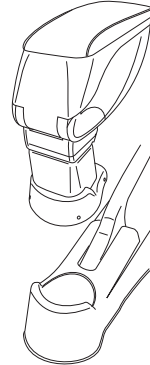

KIA

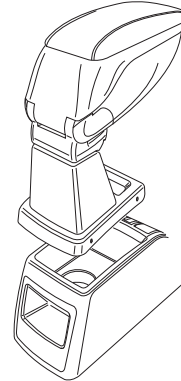

LANCIA

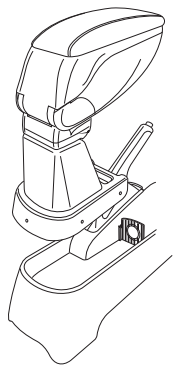

MAZDA

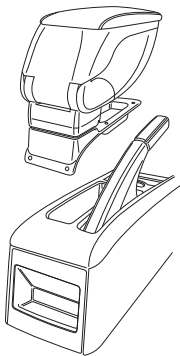

MERCEDES

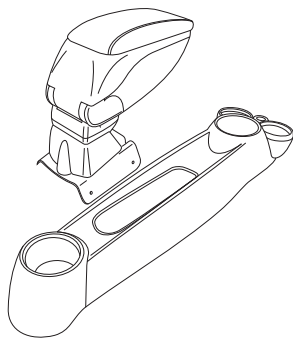

MINI

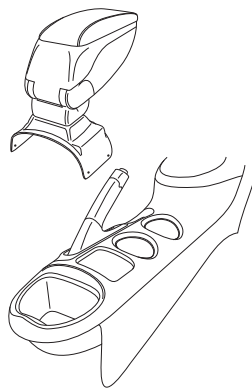

NISSAN

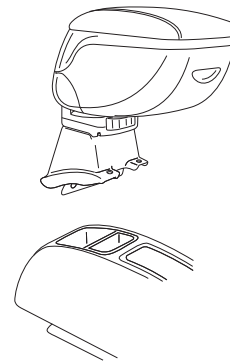

OPEL

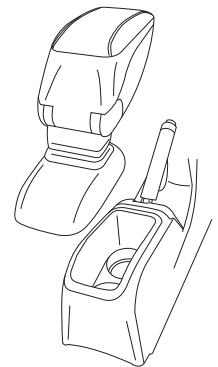

PEUGEOT

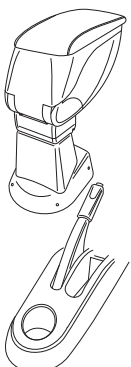

RENAULT

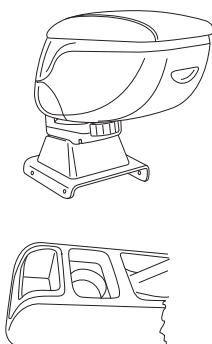

SKODA



SUZUKI

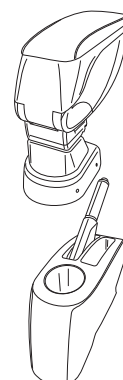

TOYOTA

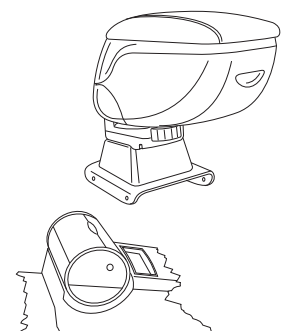

VOLKSWAGEN