

Art. 90452

HANDLE



IT Attacco fisso per manubri

Universale per manubri di diametro da 16-32 mm. Nylon ad alta resistenza. Completamente orientabile: consente l'utilizzo e la visualizzazione degli accessori sia in verticale che in orizzontale. DUO-LOCK system: per un fissaggio semplice e rapido. Compatibile con tutti gli accessori e custodie OPTILINE.

FR Fixation fixe spécifique pour guidons

Universel pour guidons avec diamètre de 16-32 mm. Nylon haute résistance. Entièrement réglable: permet l'utilisation et l'affichage des accessoires soit en vertical soit en horizontal. Système DUO-LOCK: pour une fixation rapide et facile. Compatible avec tous les accessoires et étuis OPTILINE.

DE Feste Bindung für Lenker

Universal für Lenkstangen von Ø 16 bis 32 mm. Hochbeständiges Nylon. Voll einstellbar: ermöglicht die Verwendung des Zubehörs vertikal und horizontal. DUO-LOCK-System: einfache und schnelle Befestigung. Kompatibel mit allen OPTILINE Zubehörteilen und Koffern.

EN Handlebar mount

Universal for handlebars from Ø 16 to 32 mm. Heavy duty nylon. Fully adjustable: allows the use of the accessories vertically and horizontally. DUO-LOCK system: easy and quick fixing. Compatible with all OPTILINE accessories and cases.

ES Enganche fijo específico para manillares

Universal para manillares con diámetro entre 16-32 mm. Nailon de alta resistencia. Totalmente ajustable: permite el uso y la visualización de los accesorios tanto en vertical como en horizontal. Sistema DUO-LOCK: para una fijación rápida y fácil. Compatible con todos los accesorios y estuches OPTILINE.

NL Stuurbevestiging

Universeel voor sturen van Ø 16 tot 32 mm. Zwaar uitgevoerd nylon. Volledig verstelbaar: maakt het gebruik van de accessoires verticaal en horizontaal mogelijk. DUO-LOCK-systeem: eenvoudige en snelle bevestiging. Kompatibel met alle OPTILINE accessoires en koffers.

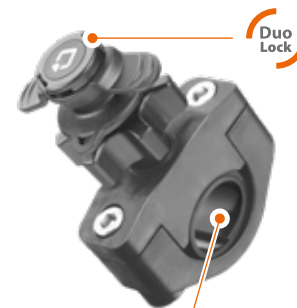

Ø 16 ~ 32 mm

 **Optiline**

LAMPA S.p.A.
Via G. Rossa, 53/55,
46019 Viadana (MN) ITALY
Tel. +39 0375 820700
UNI EN ISO 9001:2015
Certified Company
service@lampa.it
www.optiline.it

Garanzia / Warranty



Made in China



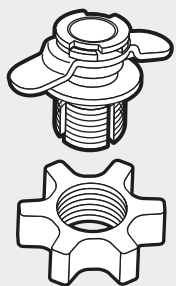

Vite con testa ad esagono
Hexagon socket screw



2 x

Brugola ad esagono
Hallen Key

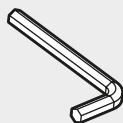

Spessori
Spacers

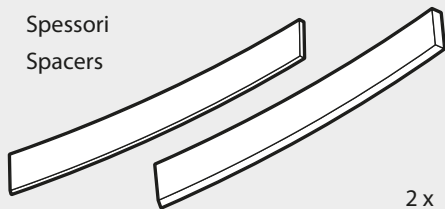

2 x

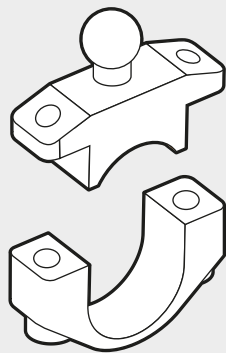

1

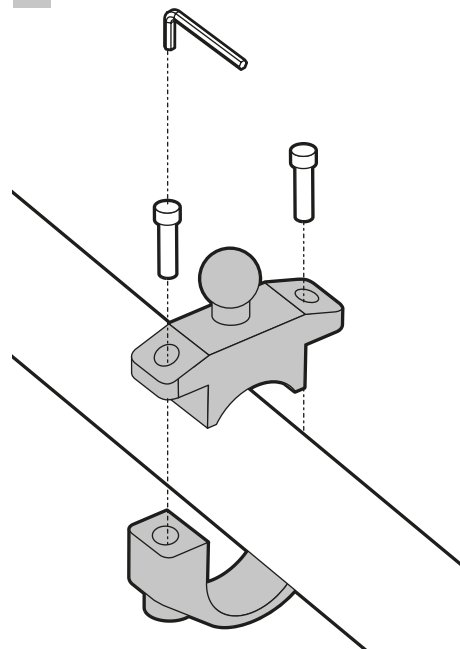

2



OK



NO

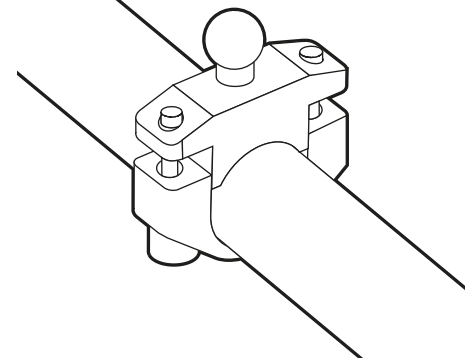

3

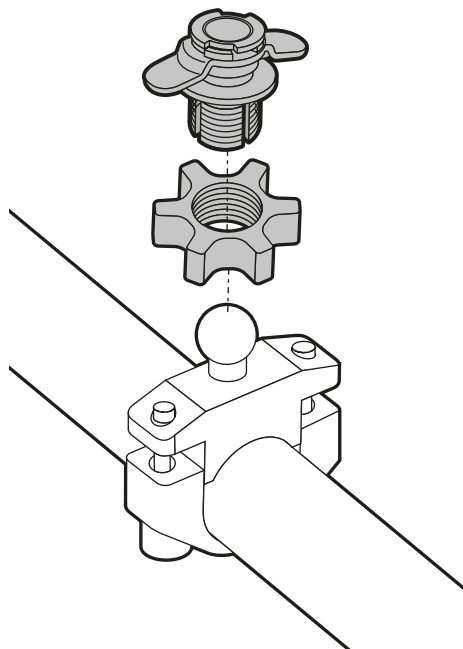

4

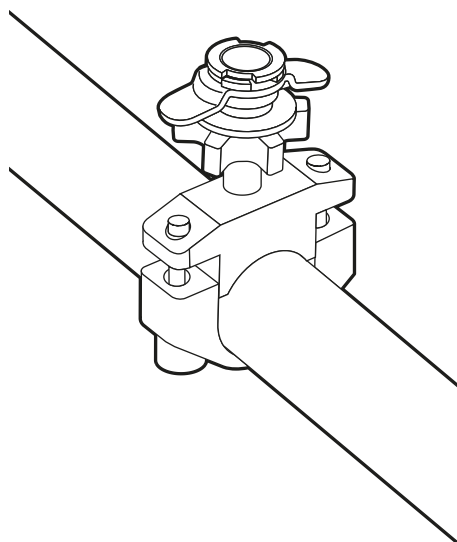

Video di installazione
Installation video



Allentare il dado prima di regolare il supporto per evitare di danneggiare l'articolo.

Loosen the nut before adjusting the mount to avoid damaging the item.

Desserrez l'écrou avant de régler le support pour éviter d'endommager l'article.

Lösen Sie die Mutter, bevor Sie den Halter einstellen, um eine Beschädigung des Gegenstands zu vermeiden.

Afloje la tuerca antes de ajustar el soporte para evitar dañar el artículo.

Draai de moer los voordat u de houder aanpast om beschadiging van het item te voorkome

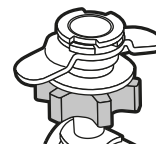

Attenzione: Le viti potrebbero allentarsi a causa di circostanze incontrollabili, è sufficiente controllarle e serrarle prima dell'installazione.

Warning: Screws might loosen due to uncontrollable circumstances, simply check and tighten it prior to installation.

Attention: Les vis peuvent se desserrer en raison de circonstances incontrôlables, il vous suffit de les vérifier et de les serrer avant l'installation.

Warnung: Die Schrauben können sich aufgrund unkontrollierbarer Umstände lösen, Sie müssen sie nur vor der Installation überprüfen und festziehen.

Advertencia: Los tornillos pueden aflojarse debido a circunstancias incontrolables, solo necesita verificarlos y apretarlos antes de la instalación.

Waarschuwing: Schroeven kunnen losraken als gevolg van oncontroleerbare omstandigheden, controleer en draai ze gewoon vast voordat u ze installeert.