

N20004

ORIGINE RL RAILING

X

CX series BARS

+

P

RL FEET

- I** Istruzioni di montaggio
- EN** Fitting instructions
- F** Instructions de montage
- D** Montageanleitung
- E** Instrucciones de montaje
- P** Instruções de montagem
- NL** Montage-instructies
- S** Monteringsanvisning
- FIN** Asennusohje
- EST** Paigaldusjuhend
- LAT** Stiprināšanas instrukcija
- LT** Pritvirtinimo instrukcijos
- PL** Instrukcja montażu
- RUS** Инструкции по установке
- CZ** Návod na montáž
- SK** Návod na montáž
- SLO** Navodila za pritrjevanje
- HR** Uputa za sastavljanje
- H** A felszerelés módja
- GR** Οδηγία συναρμολόγησης
- TR** Montaj talimatları
- BG** Инструкции за монтаж
- SRB** Uputstva za montažu



91CA0239 r03

Max **100** Kg.

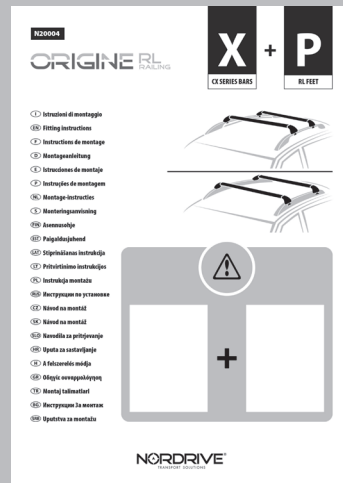
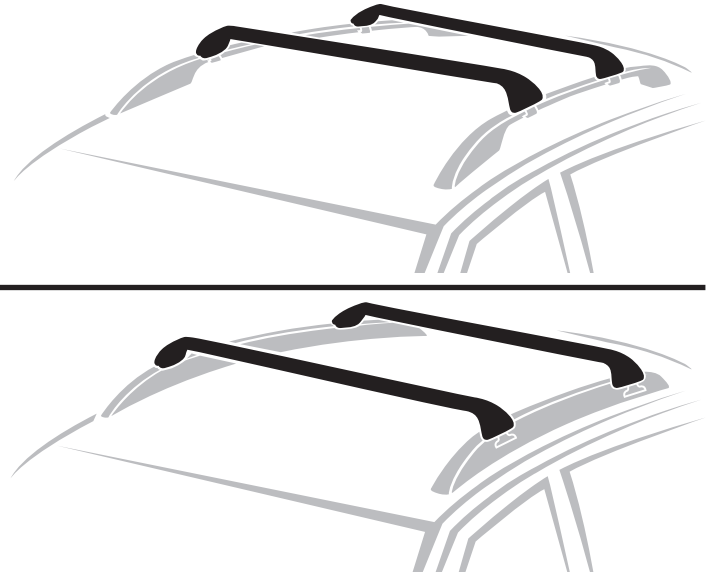



Safety Regulations

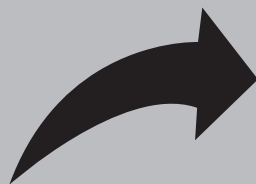

- I** Leggere il libretto di sicurezza e garanzia incluso nel prodotto prima dell'uso. Per maggiori informazioni visita il sito www.nordrive.it o contattare direttamente il rivenditore locale.
- EN** Before using this product, please read the enclosed safety and warranty booklet. For more information please visit www.nordrive.it or contact your local dealer.
- F** Avant d'utiliser ce produit, veuillez lire le livret de sécurité et de garantie inclus. Pour plus d'informations, visitez le site www.nordrive.it ou contactez votre revendeur local.
- D** Bevor die Verwendung des Produkts, die Sicherheitsbroschüre und Garantieheft lesen. Für weitere Informationen empfehlen wir Ihnen die Webseite www.nordrive.it zu besuchen oder direkt den örtlichen Wiederkäufer zu kontaktieren.
- E** Antes de usar este producto, lea el folleto de seguridad y garantía incluido. Para obtener más información, visite www.nordrive.it o póngase en contacto con su distribuidor local.
- P** Antes de usar este produto, por favor leia o livro de segurança e garantia incluso. Para obter mais informações, visite www.nordrive.it ou entre em contato com seu revendedor local.
- NL** Lees voor het gebruik van dit product het bijgevoegde veiligheids- en garantieboekje. Ga voor meer informatie naar www.nordrive.it neem contact op met uw lokale dealer.
- S** Före användning av denna produkt, vänligen läs den medföljande broschyren om säkerhet och garantivillkor. För mer information vänligen besök www.nordrive.it eller kontakta er lokala återförsäljare.
- FIN** Ennen kuin käytät tätä tuotetta, lue mukana toimitettu turva- ja takuukirja. Lisätietoja on osoitteessa www.nordrive.it tai ota yhteys paikalliseen jälleenmyyjään.
- EST** Enne toote kasutamist tutvuge kaasasoleva ohutus- ja garantiijuhendiga. Lisateabe saamiseks külastage veebisaiti www.nordrive.it või pöörduge kohaliku edasimüüja poole.
- LAT** Pirms šī produkta izmantošanas, lūdzu, izlasiet pievienoto drošības un garantijas bukletu. Lai iegūtu vairāk informācijas, lūdzu, apmeklējiet vietni www.nordrive.it vai sazinieties ar vietējo izplatītāju.
- LT** Prieš pradėdant naudoti šį produktą, prašome perskaityti pridėtus saugos ir garantinius lapus. Daugiau informacijos rasite apsilankę www.nordrive.it arba tiesiogiai susisiekdami su mūsų vietiniu atstovu.

- PL** Przed użyciem tego produktu prosimy o zapoznanie się z załączoną książeczką bezpieczeństwa i gwarancji. Aby uzyskać więcej informacji, odwiedź www.nordrive.it lub skontaktuj się z lokalnym sprzedawcą.
- RUS** Перед использованием продукта ознакомьтесь с буклетом по технике безопасности и гарантией. Для получения дополнительной информации рекомендуем посетить сайт www.nordrive.it или обратиться непосредственно к местному дилеру.
- CZ** Před použitím produktu si přečtěte přiloženou bezpečnostní a záruční brožuru. Další informace najdete na www.nordrive.it nebo přímo u místního prodejce.
- SK** Pred použitím produktu, prosím naštudujte najprv priložený manuál a bezpečnostné pokyny. Pre viac informácií prosím navštívte www.nordrive.it alebo kontaktujte miestneho predajcu/ zástupcu.
- SLO** Pred uporabo proizvoda preberi priložena navodila in garancijsko izjavo. Za več informacij obiščite internetno stran www.nordrive.it ali kontaktirajte lokalnega prodajalca.
- HR** Prije uporabe ovog proizvoda, pročitajte priloženo uputstvo o sigurnosti i jamstvu. Za više informacija posjetite www.nordrive.it ili kontaktirajte svog lokalnog distributera.
- H** Használat előtt kérjük figyelmesen olvassa el a biztonsági és garanciális útmutatót. Több információért kérjük keresse fel a www.nordrive.it weboldalt vagy lépjen kapcsolatba a honi forgalmazóval.
- GR** Πριν χρησιμοποιήσετε το προϊόν, παρακαλούμε διαβάστε το φυλλάδιο ασφάλειας και εγγύησης. Για περισσότερες πληροφορίες, επισκεφθείτε το www.nordrive.it ή επικοινωνήστε με τον τοπικό σας αντιπρόσωπο.
- TR** Bu ürünün kullanmadan önce lütfen ekteki güvenli ve garanti kitapçığını okuyun. Daha fazla bilgi için lütfen www.nordrive.it adresini ziyaret edin veya yerel bayinize iletmişe geçin.
- BG** Моля преди да използвате този продукт, прочетете инструкциите за безопасност и книжката с гаранционните условия. За повече информация моля посетете www.nordrive.it или се свържете с местния дистрибутор.
- SRB** Pre upotrebu ovog proizvoda, pažljivo pročitajte priloženu knjižicu o bezbednosti i garanciji. Za više informacija, molimo vas posetite www.nordrive.it ili kontaktirajte lokalnog distributera.



N20004 FEET

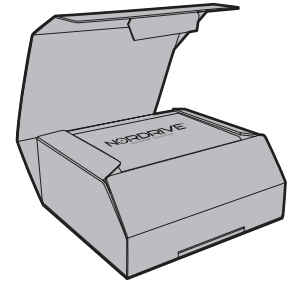

x4

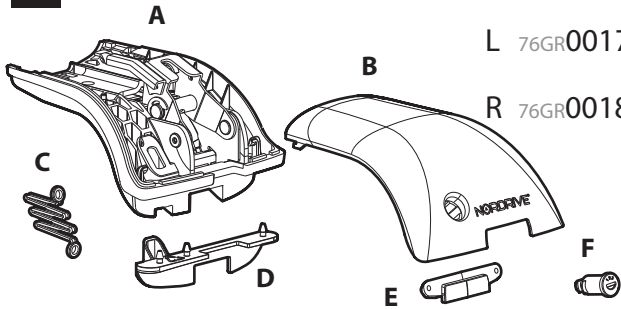

	A	B	C	D	E
L 76GR0017	76PL0012	70PL0022	43PL0009	80GO0002	74GO0001
R 76GR0018	76PL0013	70PL0023	43PL0009	80GO0001	75GO0001
F	x1	x1	x1	x3	
71NA0001		92PL0001	72FE0002		



Imballo a parte Separate pack BARS

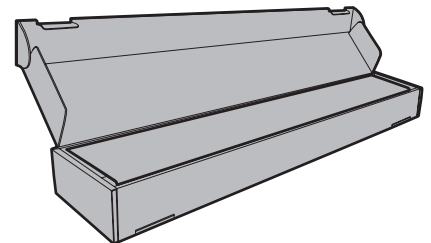

BARS (NON INCLUDE - NOT INCLUDED)

x1

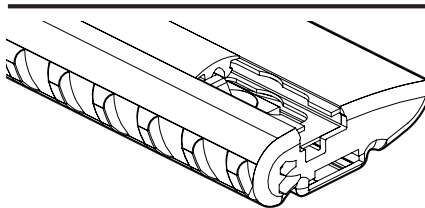

x1

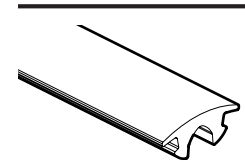

N99993



NORDRIVE SILENZIO-CX
Alluminio / Aluminium

x2

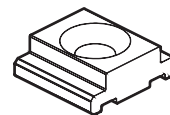

78AL0002

x2



60JT8020



Attenzione • Warning • Attention • Hinweise • Advertencia

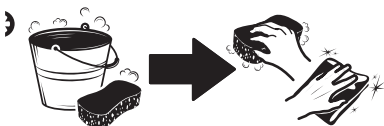

Fronte • Front • Vorderseite

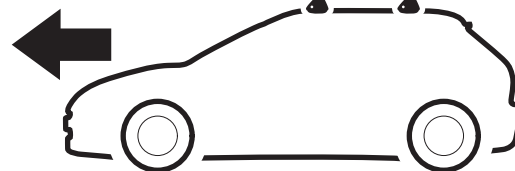

Fronte • Front • Vorderseite



Retro • Back • Rückseite

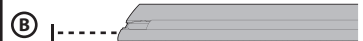

cm A ≥ cm B

OK



NO

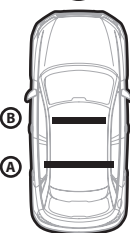



1

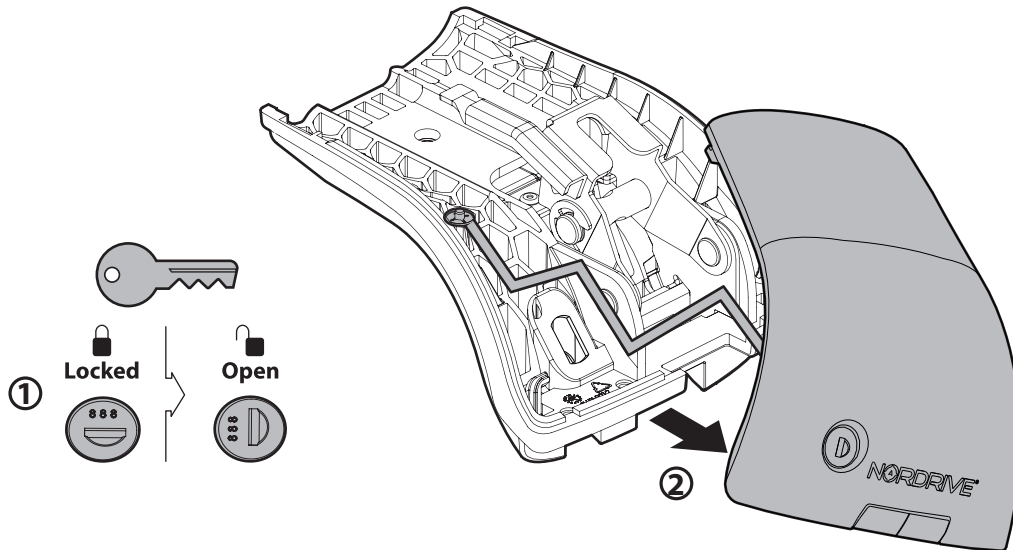

x4

2

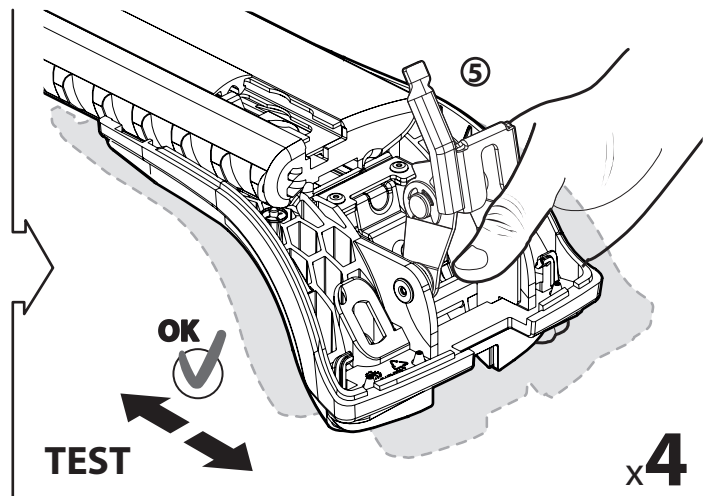
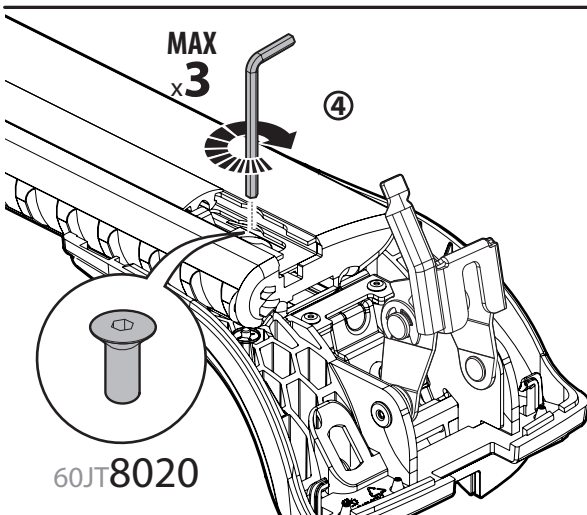
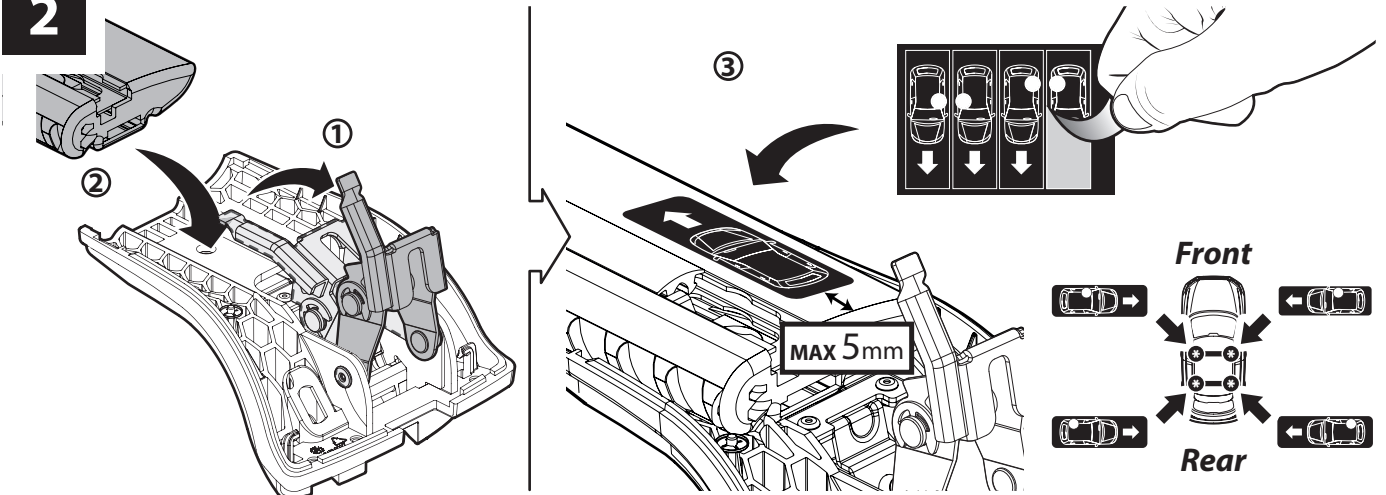

x4



- I** Passare al manuale **F** / **K** e seguire le istruzioni come indicato
- EN** Switch to manual **F** / **K** and then follow the instructions as indicated
- F** Passez au manuel **F** / **K** et suivez les instructions comme indiqué
- D** Das Handbuch **F** / **K** konsultieren und die Anleitungen wie angegeben auf Kopfzeile der Seite folgen.
- E** Vaya al manual de **F** / **K** y siga las instrucciones que se indican
- P** Passe para o manual **F** / **K** e siga as instruções
- NL** Schakel over op manuele **F** / **K** en volg dan de instructies zoals hierboven aangegeven.
- S** Byt till manual **F** / **K** och följ där instruktionerna enligt ovan.
- FIN** Vaihda manuaaliseen **F** / **K** -sarjaan ja noudata sitten yllä olevia ohjeita.
- EST** Avage **F** / **K** juhend ja järgige ülal toodud juhiseid.
- LAT** Pārslēdzieties uz manuālo **F** / **K** un pēc tam izpildiet norādījumus, kā norādīts iepriekš.
- LT** Pereikite į vadovą **F** / **K** ir tuomet sekite instrukcijas, kaip nurodyta aukščiau.
- PL** Przelącz na ręczny **F** / **K**, a następnie postępuj zgodnie z instrukcjami, jak wskazano powyżej.
- RUS** Перейдите к руководству по **F** / **K** и следуйте инструкциям, указанным в заголовке страницы.
- CZ** Přejděte do příručky **F** / **K** a postupujte podle pokynů uvedených v záhlaví stránky.
- SK** Prejdite na návod **F** / **K** a postupujte podľa pokynov uvedených vyššie.
- SLO** Zamenjajte na navodila **F** / **K** in potem jim sledite kot je navedeno zgoraj.
- HR** Prebacite se na priručnik **F** / **K** i zatim slijedite gore navedene upute.
- H** Váltson át az **F** / **K** használati útmutatójára és kövesse a fenti utasításokat.
- GR** Μεταβείτε στο φυλλάδιο του **F** / **K** και κατόπιν ακολουθήστε τις οδηγίες που φαίνονται παραπάνω.
- TR** Manuel **F** / **K** 'ye geçin ve ardından yukarıda belirtilen talimatları izleyin.
- BG** Преминете към ръководството **F** / **K** и след това следвайте инструкциите по-горе.
- SRB** Pređite na priručnik **F** / **K** a zatim sledite gore navedena uputstva.

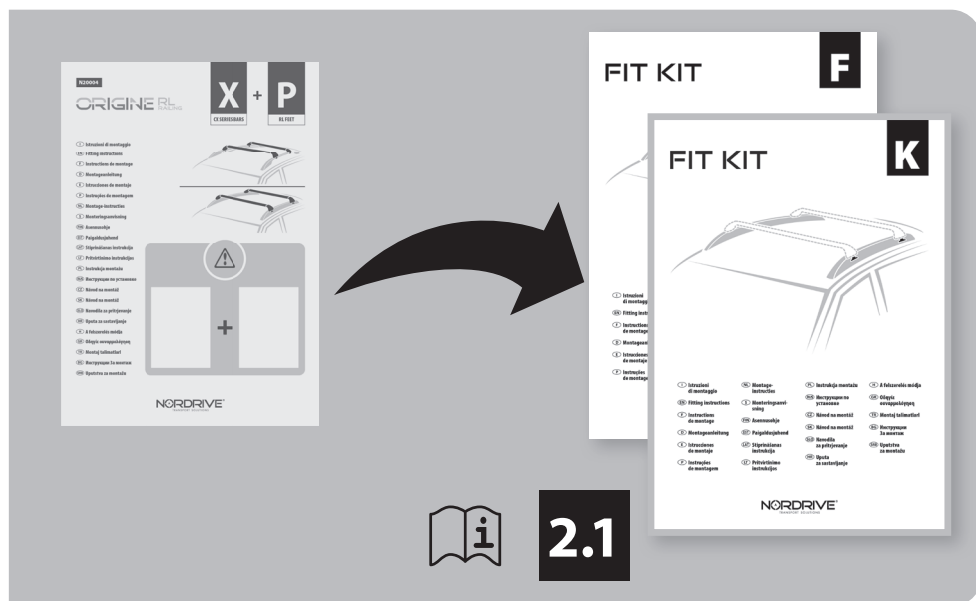

3

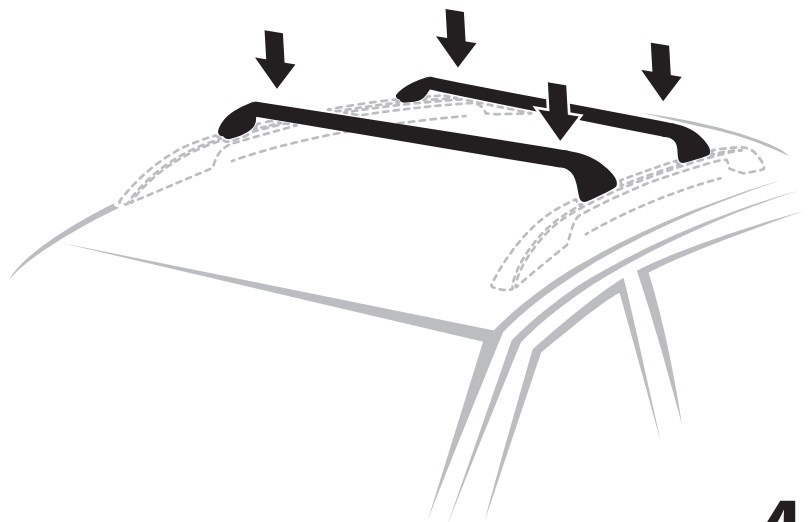
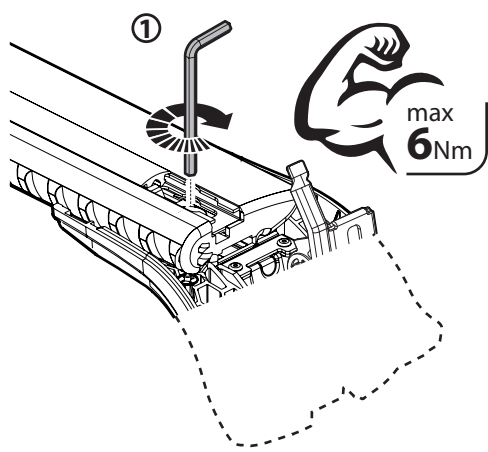

x4

4



5

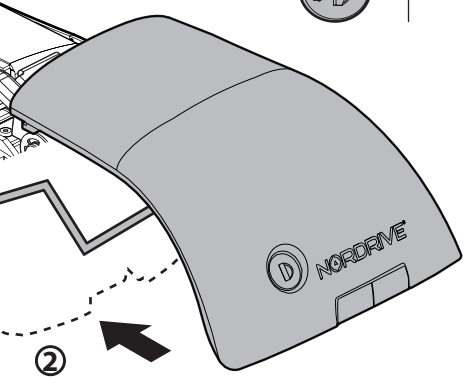
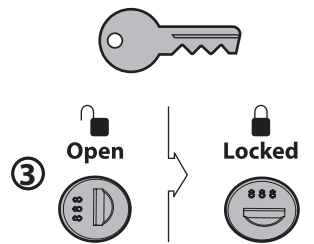
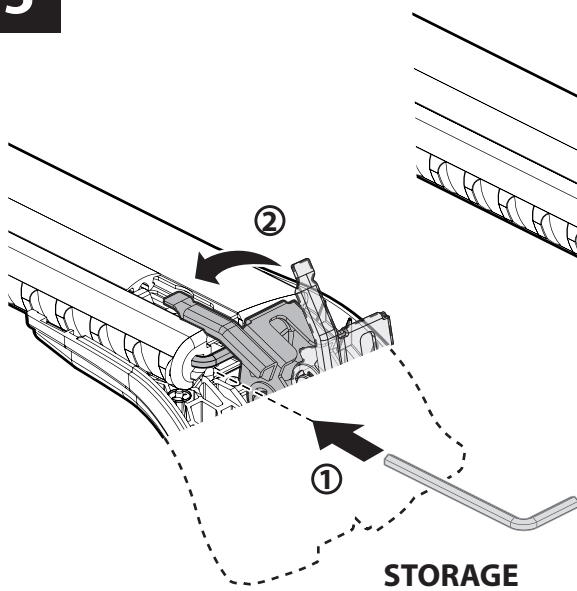

x4



Attenzione • Warning • Attention • Hinweise • Advertencia

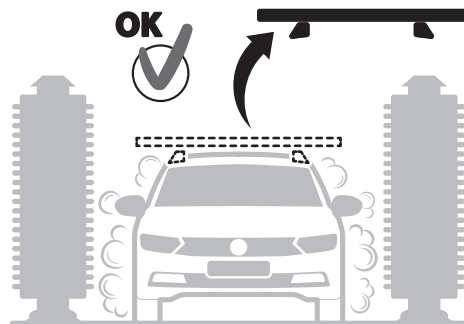
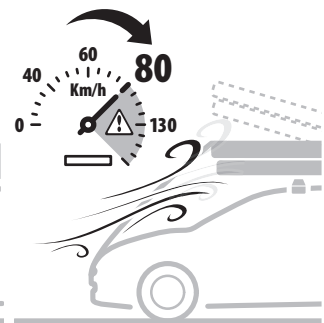
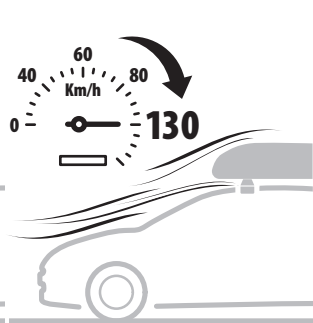
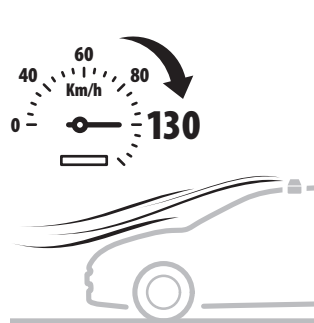
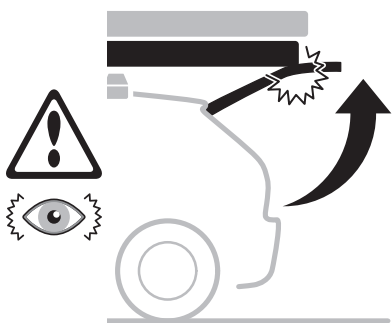
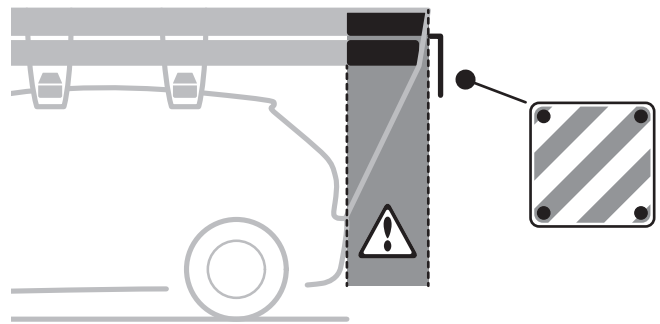
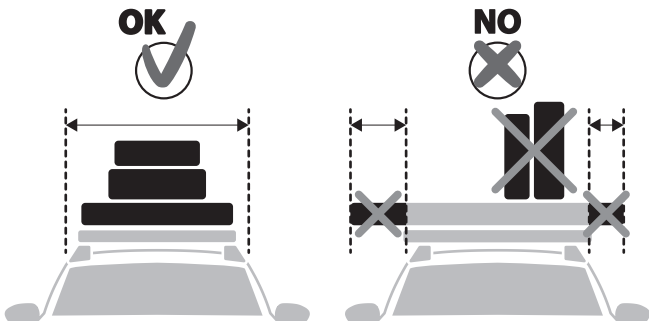
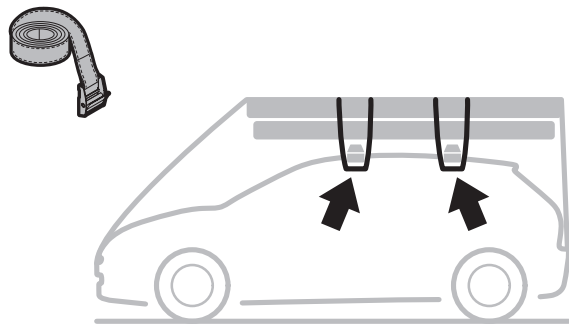
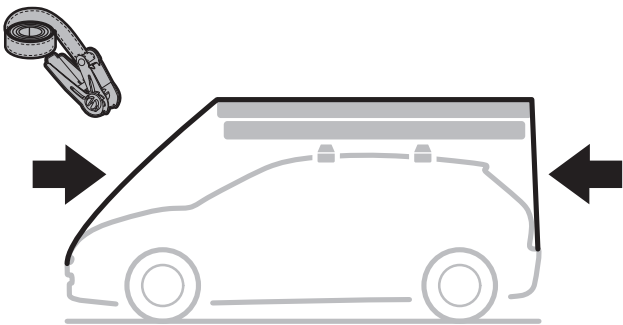
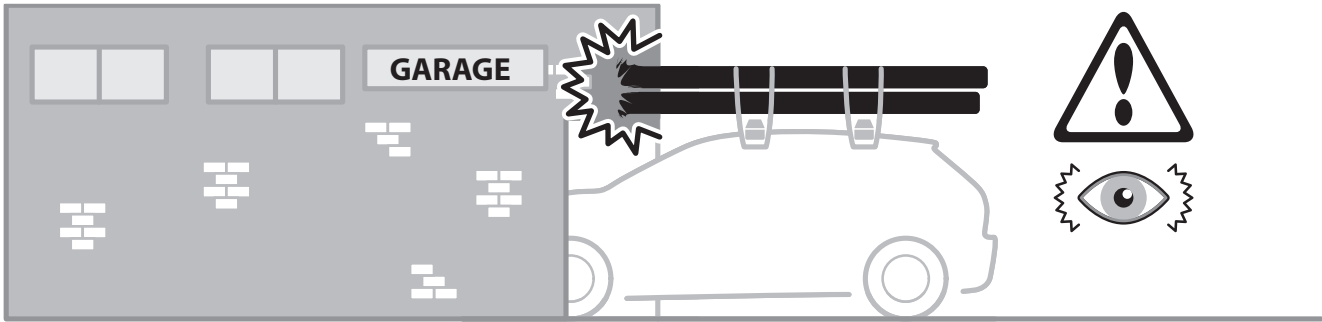



Attenzione • Warning • Attention • Hinweise • Advertencia

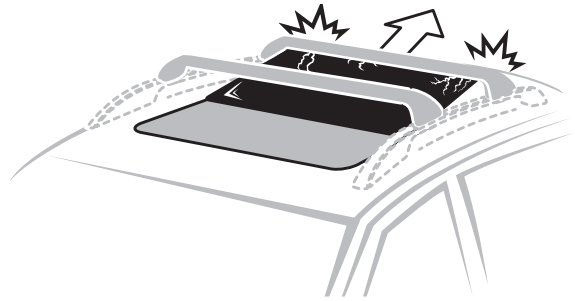
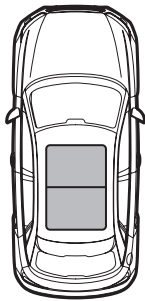
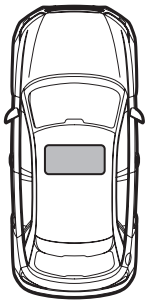

0100 Km

Pit-stop / Check!

0250 Km

Pit-stop / Check!

0500 Km

Pit-stop / Check!

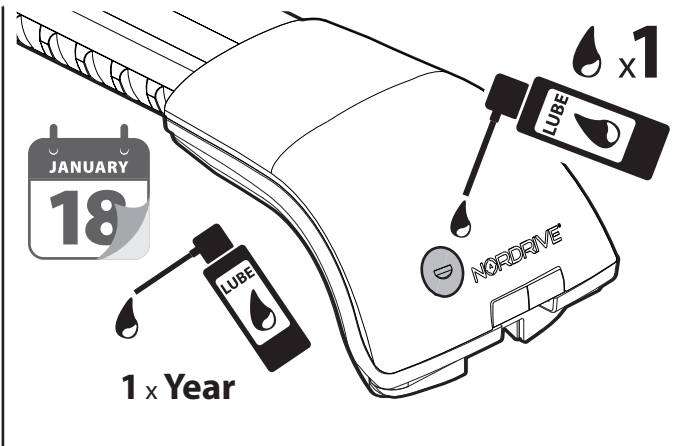
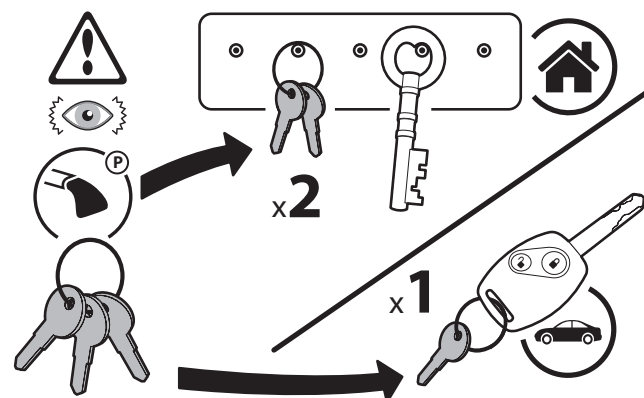
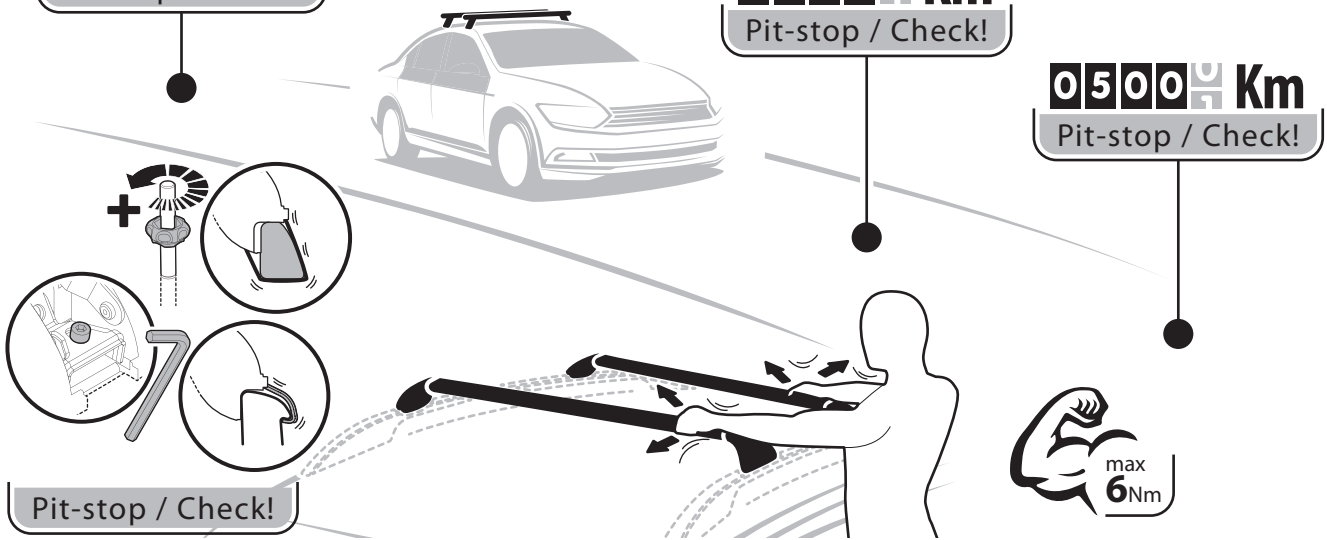

- (I) Lotto di produzione da comunicare per eventuali ricambi
- (GB) Production lot number to be communicated for any spare parts
- (F) Lot de production à communiquer pour toute pièce de rechange
- (E) Lote de producción a comunicar por cualquier repuesto
- (D) Produktionscharge für eventuelle Ersatzteile

Lot.

NORDRIVE®
TRANSPORT SOLUTIONS

**NORDRIVE® is a registered trademark of
LAMPA S.p.A.**

Via G. Rossa 53/55, 46019 Viadana (MN) ITALY

Tel. +39 0375 820700 - UNI EN ISO 9001:2015

Certified Company - service@lampa.it

www.nordrive.it www.lampa.it